



Pneumatic Vacuum Elevator PVE52 (Three passenger) 

Vacuum Elevator PVE52 (1316)

Three passenger - Wheelchair accessible

TECHNICAL SPECIFICATIONS

General

- External cylinder diameter: 1316 mm
- Rated Load: 238kg (Three passenger)
- Speed: 0.10 m/s
- No pit required. Bottom level floor must be 100% level as elevator rests on existing floor
- No hoistway required
- Minimum overhead clearance:
 - o Standard Head Unit: 2700 mm
 - o Split Unit: 2450 mm
- Penetration required to install through floors and ceilings: 1389 mm

Mechanical Requirements

- 220 V, 60/50 Hz, 35amp single phase power supply
- 6 turbine motors located in pump using a total of 6kW

Cabin

- Entrance width opening: 813 mm
- Internal cabin height: 2007mm
- Internal cabin diameter:
 - o Between columns: 1090 mm
 - o Without columns: 1210 mm
- Automatic LED lighting and cabin fan

- Door openings: same side (in-line) and walk through (180°).
 - o All doors are hinged on top left, with door swing to the left, from inside the cabin
- Door Height: 2025 mm
- Height to top of Door Closer : 2071 mm
 - o Each landing level specified will include only one door
- 24 Volt electrical circuits with all controls in cabin
- Push button call controls with precise leveling at each landing
- Telephone

Safety

- Automatic descent to ground level at safety speed in the event of a power failure.
- Mechanical emergency brakes within 5cm of freefall in vacuum loss or catastrophic failure.
- Electromechanical interlocks at each landing.
- Alarm
- Warranty: 24 month limited warranty from installation
- Machinery Directive 2006/42/EC
- CE Marking

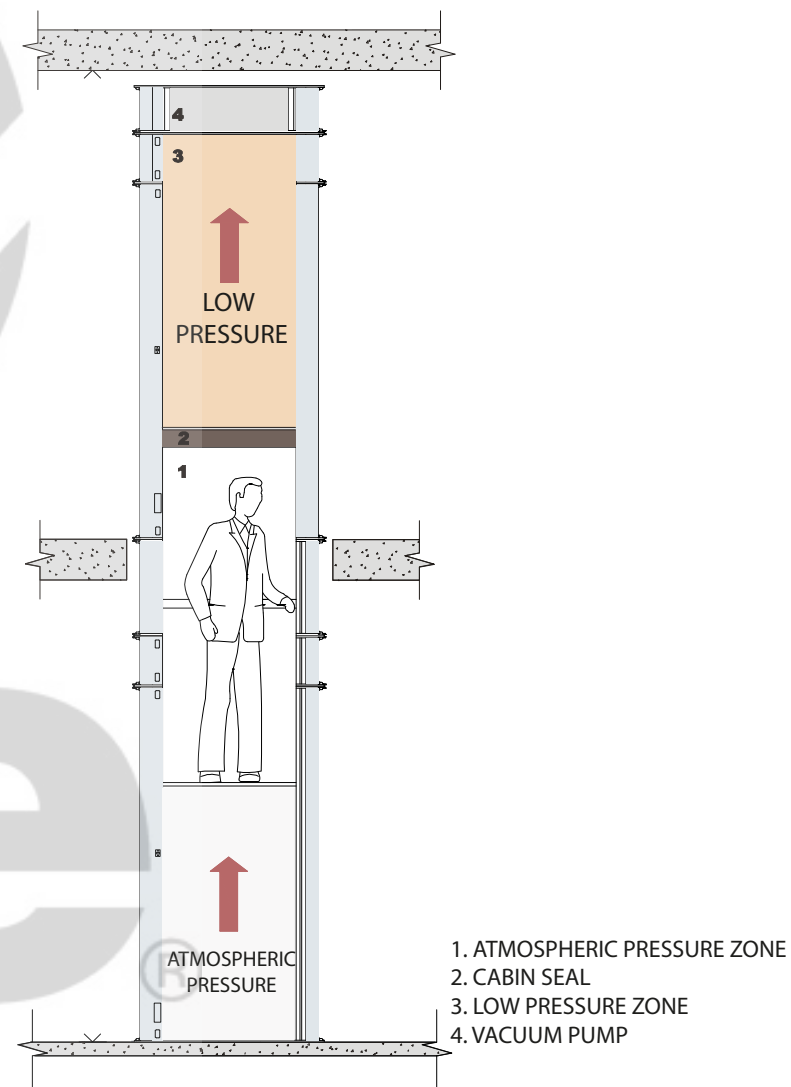

* Technical data subject to change. PVE reserves the right to change the information in this document without prior notice.

Vacuum Elevator PVE52 (1316)

Three passenger - Wheelchair accessible

STANDARD COLORS

SPECIAL COLORS

WHITE

NAVY GREY

LIGHT GREY

BLACK

TAUPE



Information contained herein is the property of Pneumatic Vacuum Elevators Llc. No reproduction or disclosure of this information may be made by the recipient to any person or organization without the written consent of Pneumatic Vacuum Elevators Llc.

Vacuum Elevator PVE52 (1316)

Three passenger - Wheelchair accessible

VACUUM MOTOR CONFIGURATIONS

The vacuum system is the “engine” and machinery through which this residential elevator functions. Currently vacuum elevators are installed in two different vacuum motor configurations:

Head Unit - Standard

In the head unit configuration, the vacuum system is located directly on top of the upper floor vertical cylinder of the pneumatic vacuum elevator.

The electrical control panel is inside, and the only installation requirements are to connect to a 220v outlet near the machinery.

This format is best in homes that have sufficient height on the top floor
(Minimum height for installation 2700mm)

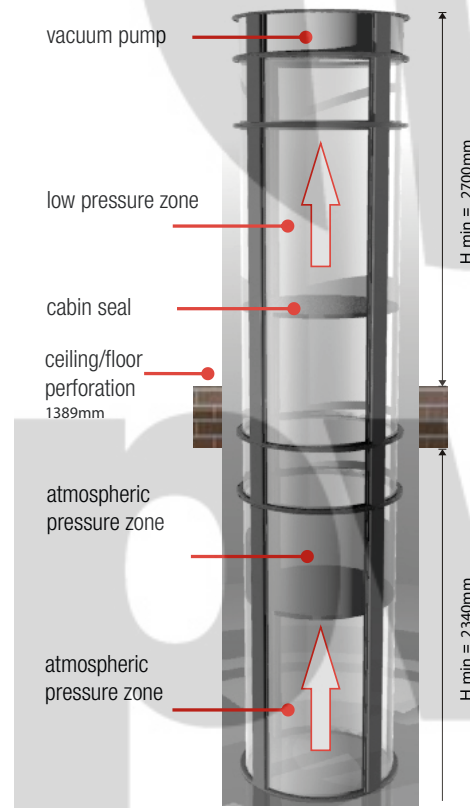

Split Unit

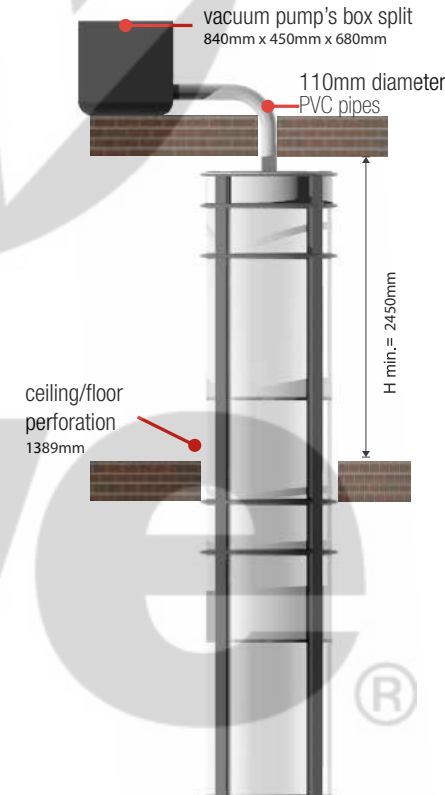

In the split unit configuration, the vacuum system is located in a split box that can be installed at a distance of 10 meters from the top of the vacuum elevator. The split system piping is connected to the top of the cylinder via two 110mm diameter PVC pipes.

The electric control panel can be mounted externally as any electrical box (hanging on the wall, wardrobe ...). There is also the possibility of placing a “false head” on to locate the electrical box and the PVC pipes are connected.

This format is required when the height of the top floor is less than 2700mm
(Minimum height for split installation 2450mm).

Vacuum Elevator PVE52 (1316)

Three passenger - Wheelchair accessible 

INSTALLATION REQUIREMENTS - HEAD UNIT STANDARD CONFIGURATION

- Minimum height required at the ground floor is 2340mm.
- Minimum required height at the upper floor is 2700mm.
- Diameter of finished through floor hole must be 1389mm.
- When installing a three or four floor elevator, all openings' circular perforations should be perfectly aligned.
- The electric feed shall be 220VAC single phase through an independent line of conductors of AWG N° 10 (6mm²); there shall be ground connection and a thermo-magnetic switch between 30A - 35A to be used exclusively for the elevator. The electrical supply is to be near the head (elevator's top portion) and it is required to leave the female electrical receptacle at the top center of the elevator.
- 220VAC (no exceptions 220VAC must be provided, 210VAC or 230VAC is not acceptable, if installation does not have 220VAC on a regular basis, a voltage regulator or transformer must be installed by home owner). Voltage fluctuations are not covered by the warranty.
- If installing a phone line a phone jack is to be provided near the power supply, but isolated.
- It is strongly recommended that a Buck Boost or voltage stabilizer be installed along with the electrical work to prevent any damage to electrical components due to voltage fluctuation.
- When installing the elevator, consider the total dimensions, as a small room will generate a higher noise level. Therefore, it is not advisable to install the split motor in a very small facility.
- There must be an opening to make way for the cylinders of 1350mm in diameter and of 2340mm length down to the ground floor. This access may be through door or window openings.
- Install a hook to bear 800kg at the ceiling where the elevator is to be installed to lift the cylinders. If it is impossible to install this hook, the minimum height at the last level shall be at least 2700mm.
- In no case must the perforation of the ceiling be less than 12cm from the wall, in order to allow for the installation tripod.

Vacuum Elevator PVE52 (1316)

Three passenger - Wheelchair accessible

INSTALLATION REQUIREMENTS - SPLIT UNIT CONFIGURATION

All requirements for the split unit model (remote location of head unit) are the same as the standard model except for the following:

- Minimum required height at the upper floor is 2450mm.
- Required space for remote location of split unit in attic or adjacent closet is 840mm x 450mm x 680mm.
- Remote location of split unit can be accommodated up to 10 m away from the elevator.
- Split unit connections require two 110mm PVC pipes to run the distance from the top of the upper floor cylinder split plate to the remote location of the split unit.
- Air supply to split unit has to be drawn from interior of residence (proper housing of split unit and air duct to interior of home required)
- Electrical power supply to be provided within direct access to remote location of split unit.

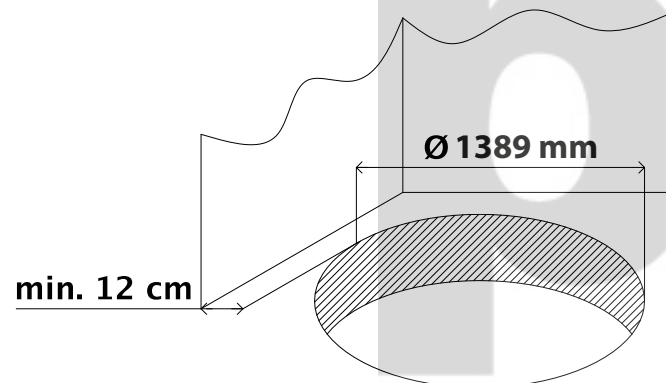



pve[®]

Pneumatic Vacuum Elevators and Lifts S.L.
C/Bronce Nro 30-31 Nave 3
Polígono Ind. Gestesa
28890 Loeches, Madrid (SPAIN)
Telephone/ fax: +34 91 886 75 39
Mobile: +34 608 502 217
www.vacuumelevators.eu
info@vacuumelevators.eu